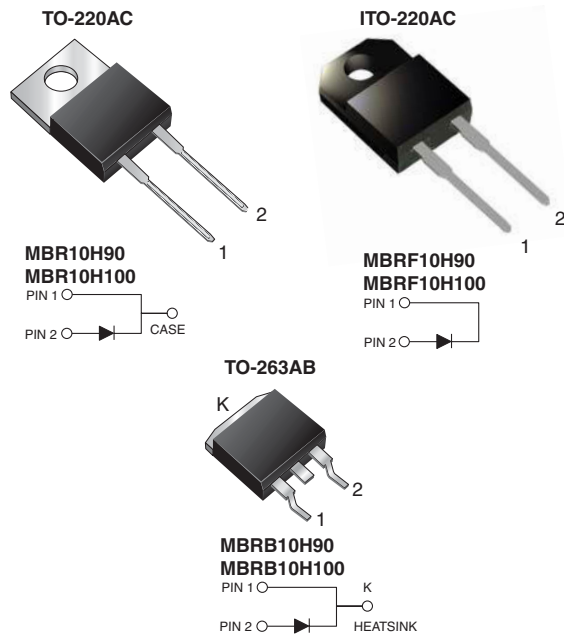

**High-Voltage Schottky Rectifier**

High Barrier Technology for improved high temperature performance

**FEATURES**

- Guardring for overvoltage protection
- Lower power losses, high efficiency
- Low forward voltage drop
- Low leakage current
- High forward surge capability
- High frequency operation
- Meets MSL level 1, per J-STD-020C, LF max peak of 245 °C (for TO-263AB package)
- Solder Dip 260 °C, 40 seconds (for TO-220AC & ITO-220AC package)
- Component in accordance to RoHS 2002/95/EC and WEEE 2002/96/EC

**TYPICAL APPLICATIONS**

For use in high frequency rectifier of switching mode power supplies, free-wheeling diodes, dc-to-dc converters or polarity protection application.

**MAJOR RATINGS AND CHARACTERISTICS**

$I_{F(AV)}$	10 A
$V_{RRM}$	90 V, 100 V
$I_{FSM}$	250 A
$V_F$	0.64 V
$I_R$	4.5 $\mu$ A
$T_J \text{ max}$	175 °C

**MECHANICAL DATA**

**Case:** TO-220AC, ITO-220AC, TO-263AB

Epoxy meets UL 94V-0 flammability rating

**Terminals:** Matte tin plated leads, solderable per J-STD-002B and JESD22-B102D

E3 suffix for commercial grade, HE3 suffix for high reliability grade (AEC Q101 qualified)

**Polarity:** As marked

**Mounting Torque:** 10 in-lbs maximum

**MAXIMUM RATINGS** ( $T_C = 25$  °C unless otherwise noted)

PARAMETER	SYMBOL	MBR10H90	MBR10H100	UNIT
Maximum repetitive peak reverse voltage	$V_{RRM}$	90	100	V
Working peak reverse voltage	$V_{RWM}$	90	100	V
Maximum DC blocking voltage	$V_{DC}$	90	100	V
Maximum average forward rectified current	$I_{F(AV)}$	10		A
Peak forward surge current 8.3 ms single half sine-wave superimposed on rated load	$I_{FSM}$	250		A
Peak repetitive reverse current at $t_p = 2$ $\mu$ s, 1 kHz	$I_{RRM}$	0.5		A
Voltage rate of change (rated $V_R$ )	dv/dt	10000		V/ $\mu$ s
Operating junction and storage temperature range	$T_J, T_{STG}$	- 65 to + 175		°C
Isolation voltage (ITO-220AC only) From terminal to heatsink $t = 1$ minute	$V_{AC}$	1500		V



<b>ELECTRICAL CHARACTERISTICS</b> ( $T_C = 25\text{ }^\circ\text{C}$ unless otherwise noted)				
PARAMETER	TEST CONDITIONS	SYMBOL	VALUE	UNIT
Maximum instantaneous forward voltage <sup>(1)</sup>	$I_F = 10\text{ A}, T_C = 25\text{ }^\circ\text{C}$	$V_F$	0.77	V
	$I_F = 10\text{ A}, T_C = 125\text{ }^\circ\text{C}$		0.64	
	$I_F = 20\text{ A}, T_C = 25\text{ }^\circ\text{C}$		0.88	
	$I_F = 20\text{ A}, T_C = 125\text{ }^\circ\text{C}$		0.73	
Maximum reverse current at working peak reverse voltage <sup>(1)</sup>		$I_R$	4.5 6.0	$\mu\text{A}$ mA

**Note:**

(1) Pulse test: 300  $\mu\text{s}$  pulse width, 1 % duty cycle

<b>THERMAL CHARACTERISTICS</b> ( $T_C = 25\text{ }^\circ\text{C}$ unless otherwise noted)					
PARAMETER	SYMBOL	MBR	MBRF	MBRB	UNIT
Typical thermal resistance	$R_{\theta JC}$	2.7	5.8	2.7	$^\circ\text{C/W}$

<b>ORDERING INFORMATION</b> (Example)					
PACKAGE	PREFERRED P/N	UNIT WEIGHT (g)	PACKAGE CODE	BASE QUANTITY	DELIVERY MODE
TO-220AC	MBR10H100-E3/45	1.80	45	50/Tube	Tube
ITO-220AC	MBRF10H100-E3/45	1.94	45	50/Tube	Tube
TO-263AB	MBRB10H100-E3/45	1.33	45	50/Tube	Tube
TO-263AB	MBRB10H100-E3/81	1.33	81	800/Reel	Tape Reel
TO-220AC	MBR10H100HE3/45 <sup>(1)</sup>	1.80	45	50/Tube	Tube
ITO-220AC	MBRF10H100HE3/45 <sup>(1)</sup>	1.94	45	50/Tube	Tube
TO-263AB	MBRB10H100HE3/45 <sup>(1)</sup>	1.33	45	50/Tube	Tube
TO-263AB	MBRB10H100HE3/81 <sup>(1)</sup>	1.33	81	800/Reel	Tape Reel

**Note:**

(1) Automotive grade AEC Q101 qualified

**RATINGS AND CHARACTERISTICS CURVES**

( $T_A = 25\text{ }^\circ\text{C}$  unless otherwise noted)

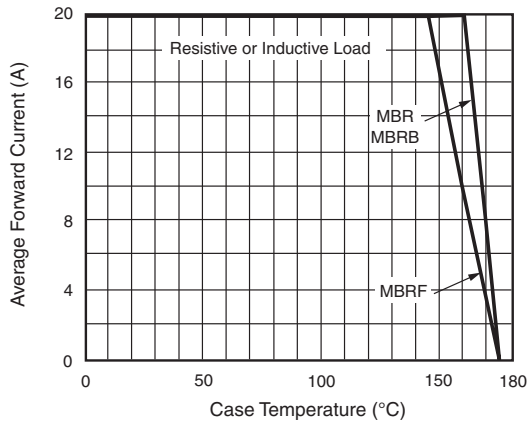

Figure 1. Forward Current Derating Curve

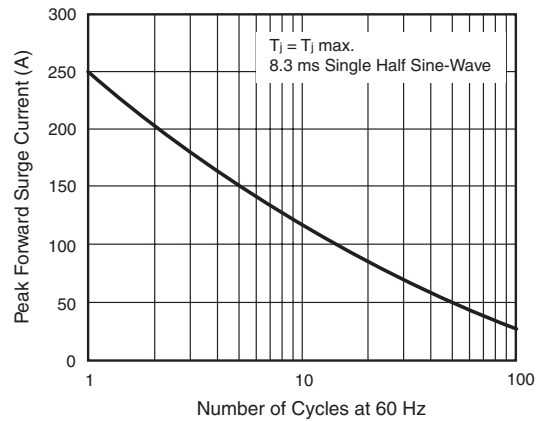

Figure 2. Maximum Non-Repetitive Peak Forward Surge Current

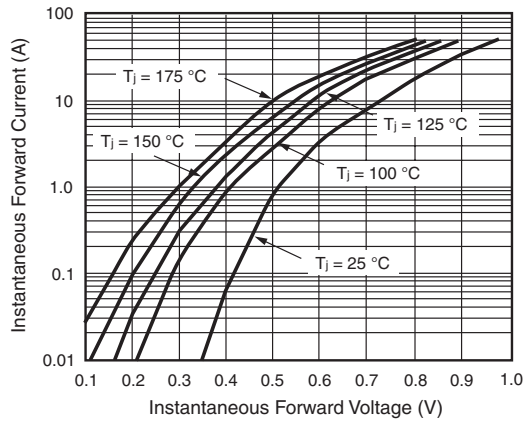

Figure 3. Typical Instantaneous Forward Characteristics

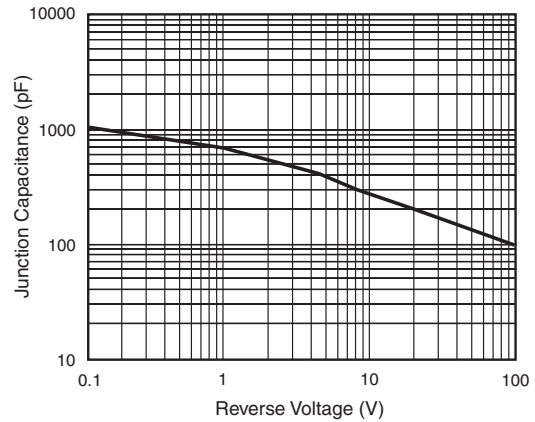

Figure 5. Typical Junction Capacitance Per Leg

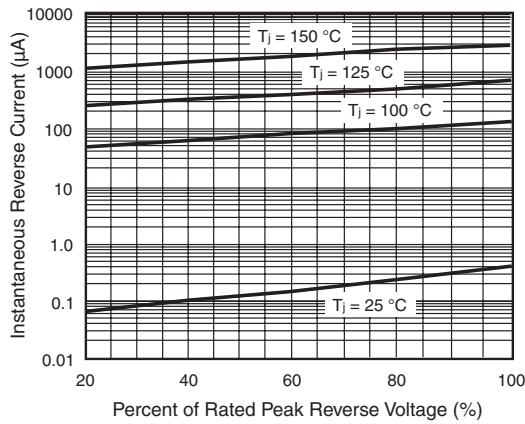

Figure 4. Typical Reverse Characteristics

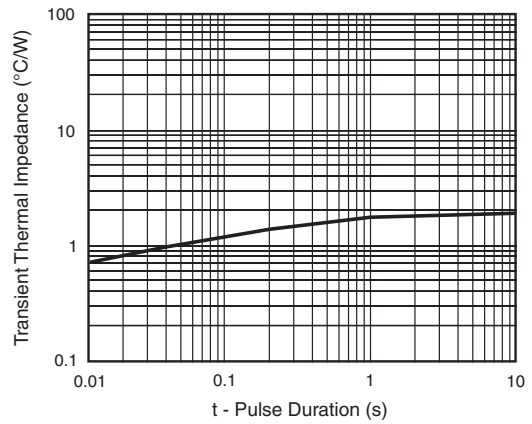

Figure 6. Typical Transient Thermal Impedance Per Leg

# MBR(F,B)10H90 & MBR(F,B)10H100



Vishay General Semiconductor

## PACKAGE OUTLINE DIMENSIONS in inches (millimeters)

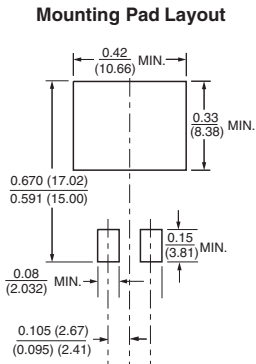
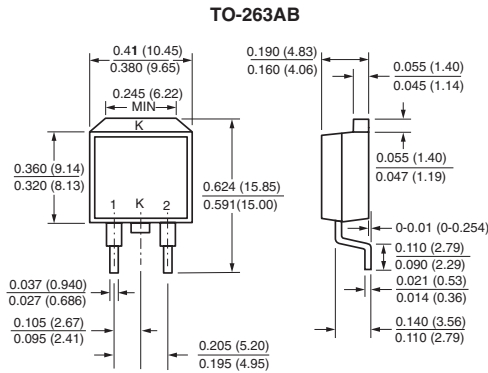
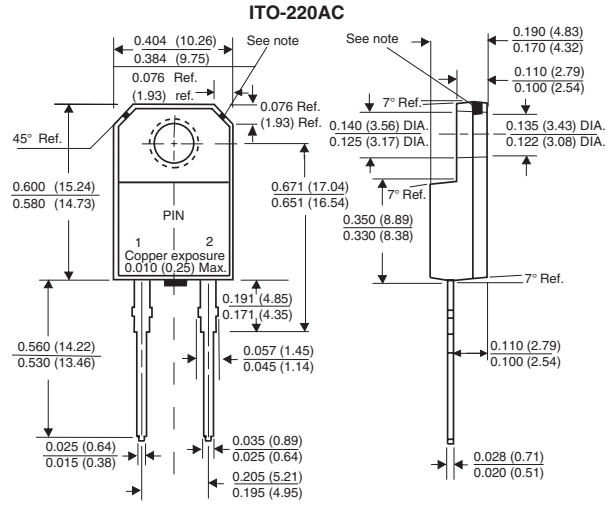
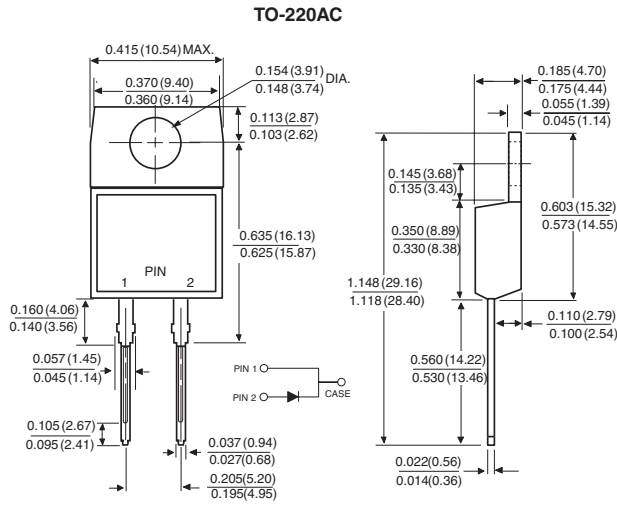



## Notice

Specifications of the products displayed herein are subject to change without notice. Vishay Intertechnology, Inc., or anyone on its behalf, assumes no responsibility or liability for any errors or inaccuracies.

Information contained herein is intended to provide a product description only. No license, express or implied, by estoppel or otherwise, to any intellectual property rights is granted by this document. Except as provided in Vishay's terms and conditions of sale for such products, Vishay assumes no liability whatsoever, and disclaims any express or implied warranty, relating to sale and/or use of Vishay products including liability or warranties relating to fitness for a particular purpose, merchantability, or infringement of any patent, copyright, or other intellectual property right.

The products shown herein are not designed for use in medical, life-saving, or life-sustaining applications. Customers using or selling these products for use in such applications do so at their own risk and agree to fully indemnify Vishay for any damages resulting from such improper use or sale.